

# McIntosh

## STEREO FM TUNER

# MR65

This Owner's Manual applies to the MR65, MR65A, and the MR65 with the MA5 Multiplex Unit installed.

### TABLE OF CONTENTS

<b>GENERAL DESCRIPTION</b>	<b>1</b>
<b>TECHNICAL DESCRIPTION</b>	<b>1</b>
<b>FRONT PANEL FACILITIES</b>	<b>2</b>
Dial Scale	2
Meters	2
Volume Control	2
Mode Selector	2
Auto. Freq. Control	3
Muting	3
<b>BACK PANEL FACILITIES</b>	<b>3</b>
External Multiplex	3
Muting Adjustment	3
Output Jacks	3
Input Jacks	3
Antenna Terminals	4
Fuse	4
<b>INSTALLATION INSTRUCTIONS</b>	<b>4</b>
<b>CONNECTING INSTRUCTIONS</b>	<b>5</b>
Monophonic FM Programs	5
Stereophonic Internal Multiplex	6
Stereophonic External Multiplex	6
Stereophonic FM-FM or FM-AM	6
Antenna Connections	6
<b>OPERATING INSTRUCTIONS</b>	<b>7</b>
Monophonic FM Programs	7
Stereophonic—Internal Multiplex	7
Stereophonic—External Multiplex	7
Stereophonic—FM-FM or FM-AM	7
Tape Recording	7
<b>ADJUSTMENTS</b>	<b>8</b>
Meters	8
Dial Lights	8
<b>GUARANTEE</b>	<b>8</b>



# OWNER'S MANUAL

ISSUE NO. 2

Reading Time 30 Minutes

Price \$1.25

MR65



# MR65 STEREO TUNER

## GENERAL DESCRIPTION

Care, in the greatest degree has been devoted on this tuner during research, design, engineering, and manufacture. So thoroughly has every detail of this equipment been planned and carried out that even its appearance speaks of the quality workmanship that is used throughout.

Once you have learned to use the MR-65 . . . experienced the operation of its controls and many functions . . . and had the opportunity to evaluate its performance . . . you will understand how effectively McIntosh design and engineering have been combined to defeat obsolescence and provide years of trouble-free performance.

The MR-65 is highly flexible in its operation. It will

receive either monophonic or stereophonic FM broadcasts. A front panel volume control and two-stage audio amplifier allow the MR-65 to operate through any type of monophonic or stereophonic equipment including pre-amplifiers, power amplifiers, tape recorders, etc.

All provisions have been made to connect an adapter for any type of multiplex system the Federal Communications Commission may adopt as a result of their present investigation and series of tests. McIntosh will manufacture a built-in multiplex adapter designed to fit in a prepared chassis opening. You can connect it with a minimum of effort. Or, if you choose, an external multiplex adapter can be connected to the jack provided on the back panel.

## TECHNICAL DESCRIPTION

The MR-65 RF tuning section uses a cascode amplifier, specially designed to amplify "weak signals" for less noise and distortion. Three flat-topped IF amplifiers reject adjacent channel interference. They give enough gain for weak signals to operate the limiters. Two cascaded limiters further improve the signal-to-noise ratio. A 4-gang capacitor and an additional tuned circuit increases RF selectivity, reducing spurious or unwanted signals.

The MR-65 uses two temperature compensated discriminators. One is a narrow-band discriminator used for ultrasonic muting, automatic frequency control, and tuning meter drive. The second one is a broad-band discriminator that gives nearly perfect audio performance. A variable-capacitance silicon diode is used in the AFC circuit instead of a conventional tube. The silicon diode improves AFC action, is unaffected by temperature changes, eliminates filament hum, and does not drift during warm-up.

The newly developed AFC circuit automatically aids tuning. During manual tuning, the MR-65 responds as if no AFC were operating. When manual tuning is completed a small difference usually remains between the lowest distortion setting and the manual tuning setting. The new circuit brings the AFC into action gradually,

over approximately a three second interval, to improve the tuning electrically and automatically. This automatic advantage is repeated each time a station is tuned on the MR-65. The AFC is completely variable by a control on the front panel.

The excellent sound quality of the MR-65 is the result of using a two-stage, low impedance, feedback audio amplifier. A front panel volume control permits convenient adjustment of output level.

The RF and IF circuits of the MR-65 are completely shielded and exceed the FCC requirements for suppression of oscillator radiation. Either a 300 ohm or 75 ohm antenna may be used with the MR-65. A VHF television antenna which is suitable for FM reception can be connected to the MR-65. When the tuner is turned off, it switches the antenna back to the TV receiver (see Antenna Connecting Instructions).

In the MR-65, a new type of mechanical tuning assembly gives smooth flywheel tuning. With direct drive to the tuning capacitor, which in turn drives the pointer, backlash is almost eliminated. For smooth, quiet action and extended life with virtually no wear, a teflon lined pointer carriage and nylon pulleys are used in the dial cord assembly.

## ELECTRICAL SPECIFICATIONS

### USABLE SENSITIVITY

3¼ microvolts at 100% modulation ( $\pm$  75 kc.) for less than 3% total noise and distortion in accordance with IHFM Standards.

### AUDIO FREQUENCY RESPONSE

Within 2 db from 20-20,000 cycles.

### DISTORTION

Less than 3% for 100% modulation (accuracy of the best available test equipment is not guaranteed below 3%).

### CAPTURE RATIO

1 to 0.7.

### MUTING

At least 60 db noise reduction between stations.

### OSCILLATOR DRIFT

Less than 25 kc. with AFC disabled; negligible with AFC in operation.

### IMAGE REJECTION

Better than 80 db at 90 mc.; better than 70 db at 105 mc.

### HUM

Better than 65 db below 100% modulation.

### OUTPUT

Approximately 4 volts; low impedance.

### ANTENNA INPUTS

300 ohms balanced; 75 ohms unbalanced.

### POWER CONSUMPTION

75 watts, 105 to 125 volts, 50-60 cycles.

### TUBE COMPLEMENT

6BN4A RF Amplifier	6SC6 2nd Limiter
6BN4A Oscillator	6BN8 Squelch amplifier and AGC Clamp
12AT7 Mixer	6C4 Meter
(3) 6AU6 IF Amplifiers	6U8A Audio amplifier
6AU6 1st Limiter	EZ80/6V4 Rectifier

## MECHANICAL SPECIFICATIONS

### DIMENSIONS

Front panel— $15\frac{5}{8}$ " by  $5\frac{1}{8}$ ". Overall depth of chassis behind front panel is  $12\frac{5}{16}$ "—A cabinet opening  $14\frac{5}{16}$ " by  $4\frac{11}{16}$ " is required to insert chassis (refer to Template).

### WEIGHT

Chassis only—21 lbs. 6 oz. In shipping carton—30 lbs. 12 oz.

Accessories supplied with the MR-65 include:

1. Instruction book,
2. Templates for mounting,
3. Folded Dipole Antenna,
4. 6 ft. shielded signal cable,
5. Mounting hardware.

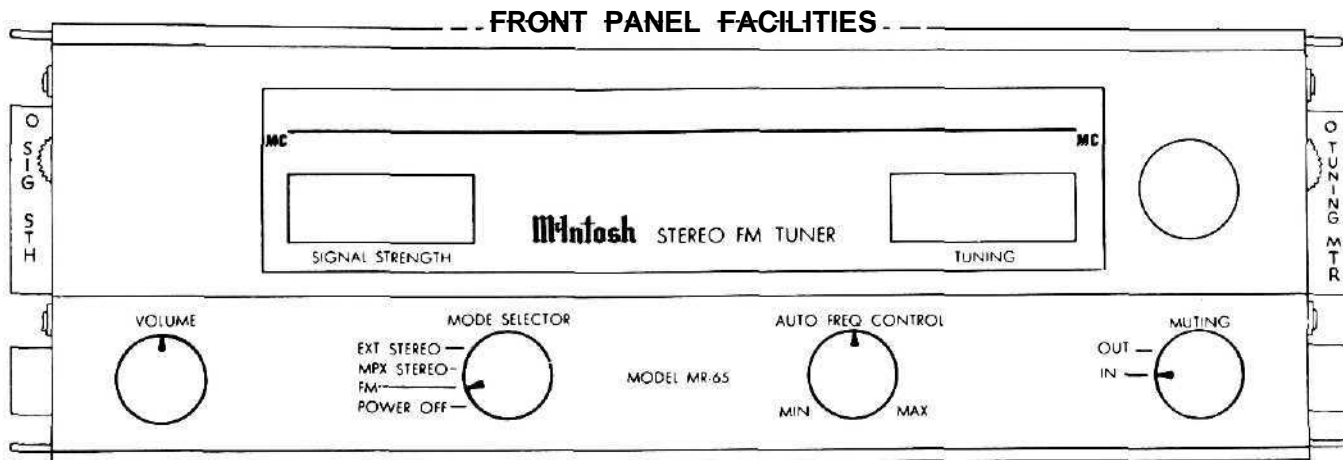

Fig. 1—Drawing of MR-65 front panel showing all controls, dial and meters.

### DIAL SCALES

The MR-65 dial has two scales. The scale, below the line, is marked in megacycles and the scale, above the line, is a logging scale. The logging scale is used to accurately re-tune any station. It is usually easier to keep a record of your favorite stations by the use of the simple numbers on the logging scale.

### METERS

In the dial assembly there are two meters. The meter on the right is the TUNING meter and the one on the left is the SIGNAL STRENGTH meter.

A station is correctly tuned when the pointer of the TUNING meter comes to rest anywhere in the black area in the center of the meter face. The meter is driven by the narrow-band discriminator. Because the meter movement is magnetically damped the pointer may need adjustment to the center of the scale at the time of permanent installation. Under the right panel end cap is a red knob with a decal beside it marked TUNING METER. This knob centers the TUNING meter. Proper adjustment is explained on page 8 under "Meter Adjustments."

The SIGNAL STRENGTH meter is driven by the 1st IF Amplifier and indicates the relative strength of signal from each station. Tuning for maximum signal strength on a weak station assists in correct tuning. If a directional FM antenna with a rotator is used the SIGNAL STRENGTH meter can indicate the proper direction for the antenna. The zero adjustment for the SIGNAL STRENGTH meter is the red knob under the left end cap identified by the SIG.ST.ADJ. decal. Proper adjustment is explained on page 8 under "Meter Adjustment."

### VOLUME CONTROL

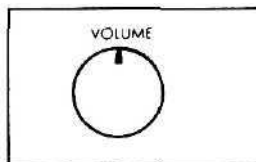

Fig. 2—Volume Control.

The volume control permits adjustment of the program loudness at the MONO OUT jacks on the back panel. The STEREO OUT jacks are not controlled by the front panel volume control.

### MODE SELECTOR

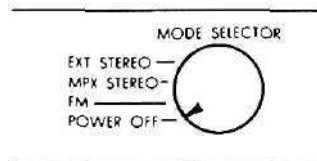

Fig. 3—The 4 position MODE SELECTOR in the POWER OFF position.

#### POWER OFF:

The MR-65 is off when the switch is turned to the extreme left or counter clockwise position. The A.C. outlet on the back panel is also turned off by this switch.

In the POWER OFF position any added program source plugged into the jacks marked STEREO IN on the back panel is connected directly to the STEREO OUT jacks. This permits an added program source to be played through the system without the MR-65 being turned on.

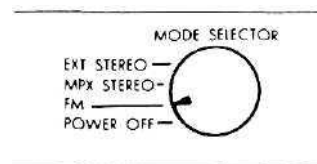

Fig. 4—MODE SELECTOR in the FM position.

#### FM:

In this position all monophonic FM programs connect to the back panel jacks marked MONO OUT. The program at these jacks is controlled by the volume control on the front panel. In this position the STEREO OUT jacks have the same monophonic program but without the volume control.

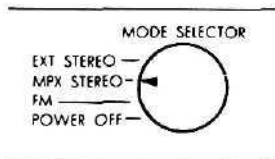

Fig. 5—MODE SELECTOR in the MPX STEREO position.

**MPX STEREO:**

In this position the output of the multiplex adapter (that can be installed on the chassis in the prepared space) connects to the jacks marked STEREO OUT on the back panel. The STEREO OUT jacks are not controlled by the volume control. The right channel program is also connected to the jacks marked MONO OUT and is controlled by the volume control.

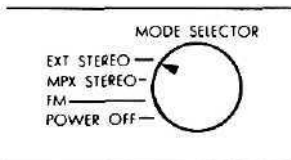

Fig. 6—MODE SELECTOR in the EXT. STEREO position.

**EXT STEREO:**

In this position the MR-65 is used for stereo broadcasts of FM-FM stereo or FM-AM stereo. The switch connects the jack STEREO IN-LEFT to the jack STEREO OUT-LEFT without amplification or volume control. The STEREO OUT-RIGHT jack is connected to the MR-65 FM program without the volume control. For FM-FM stereo another FM tuner can be plugged in the jack STEREO IN-LEFT. The MR-65 supplies the right channel while the external tuner supplies the left channel program. Similarly for FM-AM stereo, the AM tuner can be plugged in the STEREO IN-LEFT jack to supply left channel program while the MR-65 supplies the right channel program.

Again in this position the right channel program from the MR-65 is connected to the MONO OUT jacks through the volume control.

**AUTO. FREQ. CONTROL**

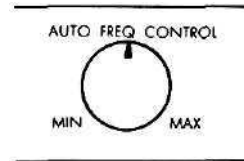

Fig. 7—The AUTOMATIC FREQUENCY CONTROL

The amount of AFC can be varied from off to full on by turning this control. Turned to the extreme left position the AFC is off. Turned to the extreme right position AFC is maximum.

The automatic action of the AFC is an exclusive McIntosh development. The AFC is electronically delayed to allow tuning without AFC. When tuning is complete, AFC is automatically restored.

**MUTING**

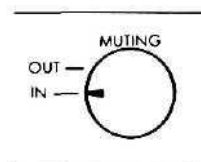

Fig. 8—Two position MUTING switch.

Between station noise is suppressed while tuning when this switch is turned to the IN position. Ultra-sonic muting, developed by McIntosh, electronically turns off the between station noise including the noises usually heard when tuning in and out of a station.

**BACK PANEL FACILITIES**

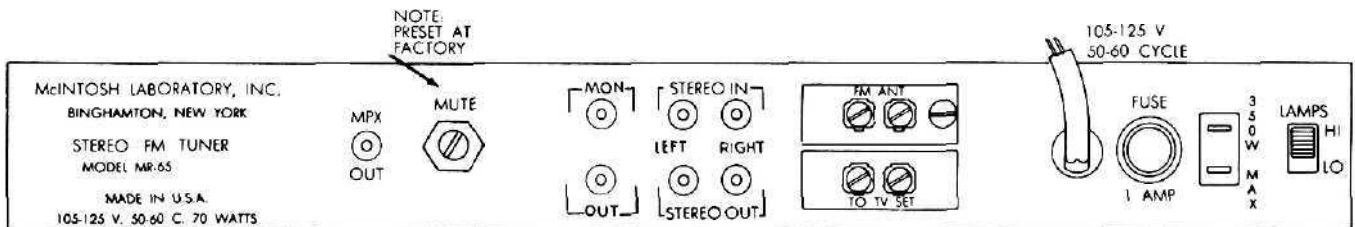

Fig. 9—Rear of chassis showing jacks, terminals, and adjustments.

**MPX OUT**

The unfiltered output of the MR-65 is connected to the MPX OUT jack to feed an external multiplex adapter. The FM program is always connected to this jack and is not affected by the front panel switching.

**MUTE ADJ**

The ultra-sonic muting feature of the MR-65 is designed to suppress noise between stations. The threshold of the muting is adjusted at the factory using precise measuring instruments. We do not recommend casual adjustment of this control. In the event it is necessary to adjust the threshold, turning the MUTE ADJ control to the right lowers the threshold of muting and turning the control to the left raises the threshold.

**MON OUT**

All monophonic programs and all right channel stereo programs tuned in on the MR-65 are connected to the

MONO OUT jacks. These jacks are connected in parallel and are fed from a low impedance feed back amplifier. The front panel volume control adjusts the program level fed to these jacks. The output level is variable up to 4 volts depending on volume control setting.

**STEREO IN**

These jacks connect a separate tuner through the front panel switching for FM-FM stereo. (See the paragraphs POWER OFF and EXT STEREO under MODE SELECTOR on pages 2 and 3 for a complete explanation.)

**STEREO OUT**

A low impedance feed back amplifier without volume control feeds the output jack marked RIGHT. The LEFT jack program connection depends on the setting of the MODE SELECTOR (See MODE SELECTOR page 2.) The output voltage of the RIGHT jack is approximately 4 volts.

## FM ANT

Either a 300 ohm balanced or 75 ohm unbalanced antenna can be connected to the MR-65. The 300 ohm input is balanced and connected internally through a special balun designed by McIntosh. The 75 ohm unbalanced antenna connection is between one side of the 300 ohm input and ground.

## TO TV SET

A VHF television antenna may be used for FM reception. An internal switch on the MODE SELECTOR connects the MR-65 between a TV antenna and a TV receiver. With the MODE SELECTOR turned to any operating position the VHF-TV antenna is disconnected from the TV set and connected to the MR-65. When the MR-65 is turned off, by rotating the MODE SELECTOR to the POWER OFF

position, the antenna is switched directly to the TV receiver.

## FUSE

The MR-65 uses a 1 ampere "Slo Blo" type fuse. The Auxiliary AC outlet is not fused.

## AC OUTLET

A maximum of 350 watts may be connected to the AC outlet. The outlet is not fused. The MODE SELECTOR on the front panel controls the power to this receptacle and turns the power off in the POWER OFF position.

## LAMPS

The dial light brightness is controlled by this switch. Simply switch to HI or LO brightness to suit your installation.

## INSTALLATION INSTRUCTIONS

The MR-65 can be installed in conventional cabinets, custom built-ins or professional equipment racks. If the MR-65 is to be placed on a bookshelf or table-top, the McIntosh Model L-66 cabinet may be used to enclose the chassis. The MR-65 is installed from the front of the cabinet. . . not from the rear. The minimum thickness of wood panels used to mount the MR-65 should be  $\frac{1}{4}$ " . . . and panels up to 1" thick may be used.

A shelf is required to support the rear of the chassis when the front panel is made of wood. It is important to make a suitable cutout in the shelf for ventilation. When mounted on a metal rack panel, a shelf is not needed.

The space in which the MR-65 will be installed should be at least  $13\frac{3}{4}$ " behind the front panel to allow about  $1\frac{1}{2}$ " for connectors. Allow at least  $16\frac{1}{2}$ " for width and  $5\frac{1}{2}$ " for height so there will be sufficient space for circulation of air. These are inside dimensions.

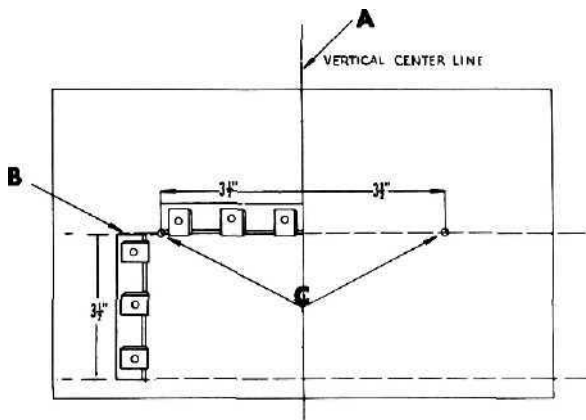

Fig. 10—Positions "A" to "C" showing the location of the vertical center line; how the measuring tool (mounting strip) is used to locate the horizontal center line, and to measure off the two points to the right and left of the vertical center line.

## MAKING THE FRONT PANEL CUTOUT

The panel is cut out using the "FRONT PANEL CUT-OUT TEMPLATE." To position the template on the front of the panel, it is necessary to make two locating holes from the back (inside) of the panel using one of the mounting strips ( $\frac{1}{2}$ " by  $3\frac{1}{2}$ ") as a measuring tool. Proceed as follows:

Measure the exact center of the proposed cut out area and scribe a vertical center line from the top of the panel down to the top surface of the shelf. See position

"A" in Fig. 11. Draw a horizontal line  $3\frac{1}{2}$ " above the shelf using one of the mounting strips as a measuring tool. See position "B" in Fig. 11. Now—place a mounting strip along the horizontal line to the left of the vertical center line and mark a point  $3\frac{1}{2}$ " left from the vertical center line. Repeat this procedure and mark a point  $3\frac{1}{2}$ " right from the vertical center line. These points should now be  $3\frac{1}{2}$ " up from the top of the shelf and 7" apart, one  $3\frac{1}{2}$ " to the left and one  $3\frac{1}{2}$ " to the right of the vertical center line. See position "C" in Fig. 11. Drill a  $\frac{3}{16}$ " hole at each point—take care to hold the drill perpendicular to the front panel so that the hole will be located accurately on the front of the panel.

Position the template on the front of the panel using the two locating holes to line it up correctly. Scribe the rectangular opening on the front panel and mark the position of the six mounting holes. Drill the six  $\frac{3}{16}$ " mounting holes before cutting the panel opening. Then cut out the opening. It is important that the cutout be just within the lines.

## MAKING THE SHELF CUTOUTS

If the installation uses a shelf, it must be cut out to provide ventilation below the chassis. To make the cut-out, use the "SHELF CUTOUT TEMPLATE." Locate the center of the shelf and scribe a line from front to back. The template is marked for panel thicknesses from  $\frac{1}{4}$ " to 1". Fold on the line that corresponds to the thickness of the panel. Place it on the shelf so that it butts against the inside of the panel. Match the center line mark on the template to the scribed center line on the shelf. Mark the position of the four holes and scribe the square ventilation opening. Drill the four  $\frac{1}{4}$ " holes and cut out the ventilation opening.

## INSTALLING THE MR-65

Remove the four screws holding the MR-65 to the shipping pallet (save these screws, you will need them if your cabinet has a  $\frac{1}{4}$ " or  $\frac{3}{8}$ " shelf.) Remove the four plastic feet.

In the mounting hardware package are four 6-32 flathead screws and eight 6-32 roundhead screws. Two of the flathead screws of the proper length are used to attach the mounting strips to the cabinet. Four of the roundhead screws of the proper length are used to attach the MR-65 to the cabinet and mounting strips. The 6-32 x  $\frac{1}{2}$ " screws are to be used with panels under  $\frac{3}{8}$ " in thickness. The 6-32 x  $\frac{1}{4}$ " screws are to be used with panels  $\frac{1}{2}$ " to 1" in thickness.

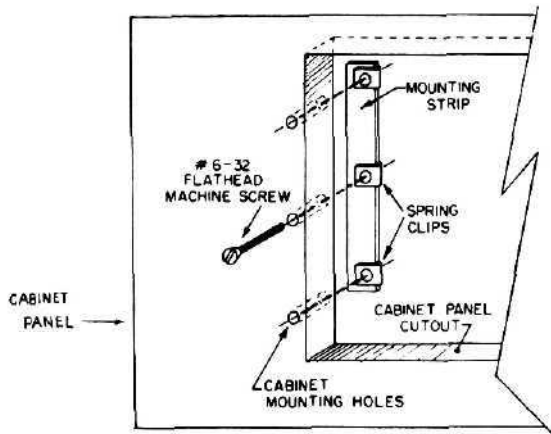

Fig. 11—Securing the mounting strip to the front panel.

Select the proper length 6-32 flathead screws and use them to install the two mounting strips behind the front panel. Be sure that the edge of the strip with the clips is toward the panel opening. Line up the mounting strips on each side of the front panel cutout so the three holes in the strip are in line with the three holes in the panel; see Fig. 11. Install the proper length flathead screws in the center hole, and drive them in so the flat-heads are flush with the panel; if necessary, countersink the two center holes.

Insert the MR-65 carefully into the panel opening from the front so that it rests on the shelf. Insert the proper length 6-32 roundhead screws into the four holes in the mounting flanges on each end of the tuner front panel and drive them in, but do not tighten.

**IF THE CABINET IS FIXED AND WILL NOT BE MOVED ABOUT, IT IS NOT NECESSARY TO SECURE THE MR-65 CHASSIS TO THE SHELF.**

If this is the case, tighten the four screws holding the front panel. If the cabinet is to be moved about, it is recommended that the MR-65 chassis be secured to the

shelf. The four 10-32 x 1/2" screws used in shipping are supplied for use if the shelf is under 3/8". Use the 10-32 x 3/4" screws if the shelf is 1/2" or 5/8" and the 10-32 x 1" screws if the shelf is 3/4" or 7/8". Secure the chassis with the proper length 10-32 machine screws, inserting them from beneath the shelf. Do not tighten the 10-32 screws until you have tightened the front panel screws. Use of the wrong length 10-32 screws may cause electrical shorting in the circuit.

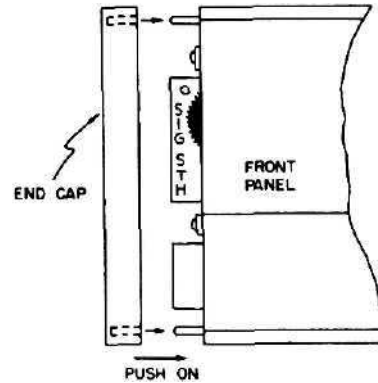

Fig. 12—Detail of how the panel end caps are fitted to the MR-65 panel.

Attach the two metal panel end caps (packed with mounting hardware) on each end of the panel by sliding onto the pins. (See Fig. 3). The end caps are held by spring tension and can easily be removed if the chassis is to be taken out of the cabinet.

#### MOUNTING IN THE L-66 CABINET

The McIntosh L-66 cabinet is supplied with complete instructions and all necessary hardware for installing the MR-65 Stereo FM Tuner. The dimensions of the L-66 are 16<sup>9</sup>/<sub>16</sub>" wide by 6<sup>11</sup>/<sub>16</sub>" high (including mounting feet) by 13<sup>3</sup>/<sub>4</sub>" deep, including the front panel and control knobs.

### CONNECTING THE MR-65 MONOPHONIC PROGRAM CONNECTIONS

#### MONOPHONIC FM PROGRAM

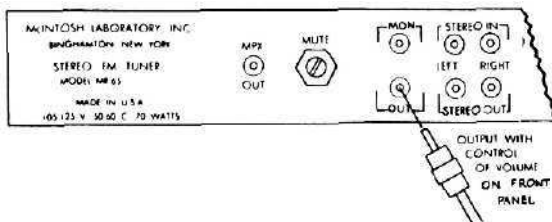

Fig. 13—Monophonic output with volume control.

The shielded cable supplied with the MR-65 is used to connect the MR-65 output jack marked MON-OUT to a high level (tuner or aux.) input of a preamplifier or directly to a power amplifier (see Fig. 13). The program

at MON-OUT jacks is controlled by the front panel volume control.

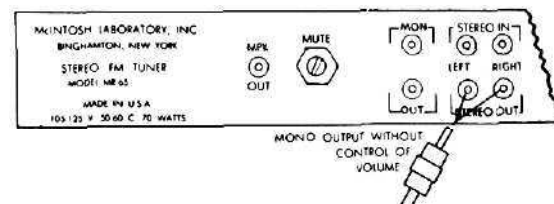

Fig. 14—Monophonic output without volume control.

If you do not wish to use the volume control on the MR-65 then the cable is plugged in one or the other of the jacks marked STEREO-OUT. (See Fig. 14). The program then is taken from the MR-65 ahead of the volume control.

### STEREOPHONIC PROGRAM CONNECTIONS

For stereophonic programs the MR-65 should be connected to a preamplifier control center. The MR-65 volume control does not change the tuner output program level at the STEREO OUT jacks.

## STEREO WITH BUILT-IN MPX

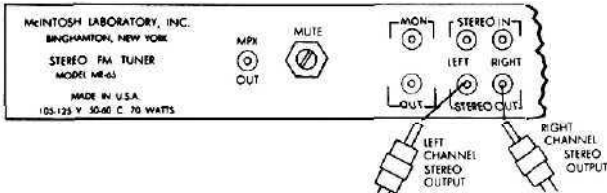

Fig. 15—Stereo output connections.

Provisions have been made to install an integrated multiplex adapter on the top surface of the MR-65 chassis. After the F.C.C. has published standards for stereo multiplex, McIntosh will manufacture such an adapter.

After the multiplex adapter has been installed on the MR-65 chassis, connections for the stereo program are made at the STEREO-OUT jacks. A shielded cable is plugged in the STEREO-OUT-LEFT jack and connected to the left tuner input on the music system's preamplifier. Plug a second shielded cable in the STEREO-OUT-RIGHT jack of the MR-65 and connect it to the right tuner input on the music system's preamplifier. Program volume is controlled at the music system's preamplifier. The volume control on the MR-65 does not operate in the stereo modes.

It is unnecessary to connect the MONO FM output jacks to the preamplifier if the MR-65 is connected for stereophonic operation. The monophonic FM program is internally connected in the MR-65 to the STEREO OUT jacks when the MODE SELECTOR is in the FM position.

## STEREO WITH AN EXTERNAL MPX ADAPTER

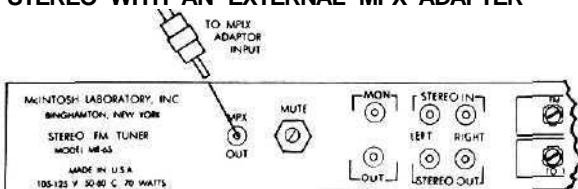

Fig. 16—Connections for an external MPX adapter.

The unfiltered output of the MR-65 is available at the jack marked MPX OUT. Plug the input of the external MPX adapter into this jack. The AC power cord for the adapter can be plugged into the AC receptacle on the MR-65. The MPX adapter will then be turned off when the tuner is turned off.

## FM-FM or FM-AM STEREO

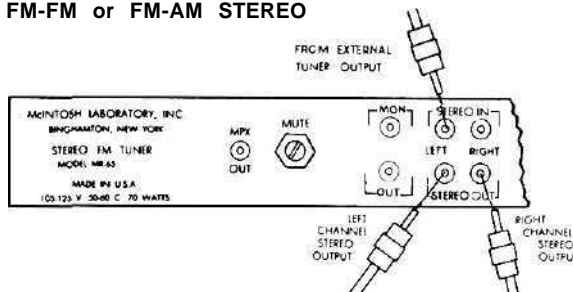

Fig. 17—Connection for external tuner for stereo.

The right channel program of FM-FM stereo or FM-AM stereo is the MR-65 program. An external tuner is used for the left channel program. The external tuner is connected by a shielded cable to the STEREO IN-LEFT jack. The left channel program (from the external tuner through the MR-65 switching) is plugged in the STEREO-OUT-LEFT jack and connected to the left tuner input of the preamplifier. The right channel program supplied by the MR-65 is plugged in the STEREO OUT-RIGHT jack and connected to the right tuner input of the preamplifier. (See Fig. 17). The MR-65 volume control does not operate for this method of operation.

## AC POWER

Plug the AC power cord in 105 volt to 125 volt, 50 to 60 cycle power line. The power used by the MR-65 is 75 watts.

## ANTENNA CONNECTIONS

With the MR-65 one of three antenna systems can be used: (1) the indoor dipole supplied with the MR-65, (2) an outdoor FM antenna, or (3) a VHF-TV antenna. In fringe areas best results will probably be obtained with the use of an outdoor FM antenna. In many areas the indoor dipole antenna is usually satisfactory. The use of a VHF TV antenna is also effective in many installations. Make a choice after consulting your dealer.

## INDOOR DIPOLE ANTENNA

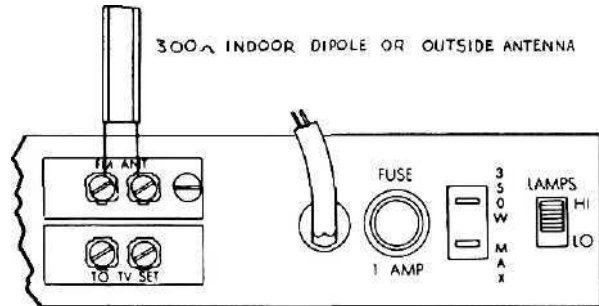

Fig. 18—Connection for 300 ohm antenna.

The flexible folded dipole antenna (300 ohm) supplied with the MR-65 is for indoor use in urban or high intensity signal areas. The flexibility of the thin flat wire assembly permits it to be placed under a rug, tacked behind the hi-fi equipment enclosure . . . or, placed in any other convenient location. In some cases, it may be necessary to "position" the antenna for best signal reception. This should be done before it is permanently located or tacked down.

To position the dipole for best results the MR-65 must be operating. The following procedure may be followed: Connect the two leads from the dipole to the terminals marked FM ANT on the rear of the chassis of the MR-65; see Fig. 18.

**IMPORTANT: BEFORE TURNING THE MR-65 ON, CHECK TO SEE THAT ALL TUBES ARE FIRMLY SEATED IN THEIR SOCKETS, AND THAT ALL PLUGS ARE CORRECTLY AND FIRMLY INSERTED.**

Turn the power on by setting the MODE SELECTOR to FM. Turn the AFC Control to MIN, the MUTING control to OUT. Open the dipole to a full "T" and tune the MR-65 to a fairly weak station. Observe the SIGNAL STRENGTH meter on the front panel as you rotate and move the dipole about. . . when the meter reads highest, the dipole is in the best position for maximum signal reception for this station. This is not a critical position; therefore you may permanently install the antenna in a position which most closely confirms to it.

**IMPORTANT: KEEP THE DIPOLE AWAY FROM METAL SURFACES, METAL DOORWAYS, ETC., AS THEY USUALLY INTERFERE WITH ITS EFFICIENCY.**

## OUTDOOR ANTENNA

An outdoor antenna is recommended for optimum performance in all areas. In fringe (outlying) areas, best results will be obtained with a highly directional FM antenna used in conjunction with a rotator. In this instance, the SIGNAL STRENGTH meter may be used as an indicator of the antenna's direction and position for maximum signal. Connect the 300 ohm antenna to the terminal screws marked FM ANT as in Fig. 18.



### CONNECTING A 75 OHM COAXIAL ANTENNA LEAD

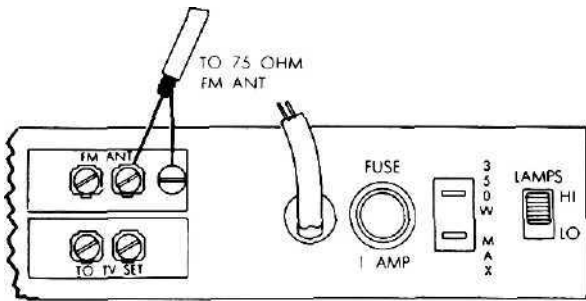

Fig. 19—Connections for a 75 ohm antenna.

An unbalanced 75 ohm antenna can be connected to the MR-65 with coaxial cable. Connect the center conductor to the right FM ANT screw and the shield to the grounding screw next to the antenna screw as in Fig. 19. The McIntosh designed balun matches the 75 ohm input to the tuner for optimum performance.

### VHF-TV ANTENNA CONNECTION

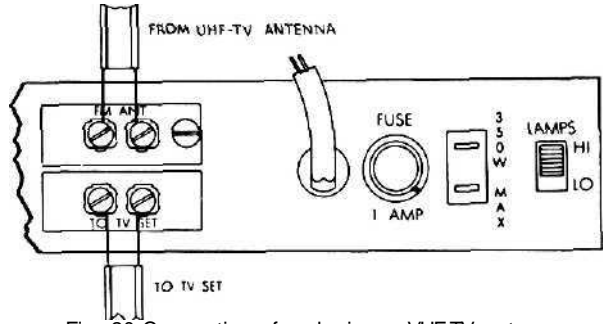

Fig. 20—Connections for sharing a VHF-TV antenna.

The MODE SELECTOR switch disconnects the VHF-TV antenna from the TV set and connects it to the MR-65. When the MR-65 is turned off the switch re-connects the antenna to the TV set.

Connect the VHF-TV antenna to the FM ANT terminals and connect a 300 ohm flat ribbon wire from the terminals marked TO TV SET to the antenna terminals on the TV set. (See Fig. 20).

### OPERATING THE MR-65

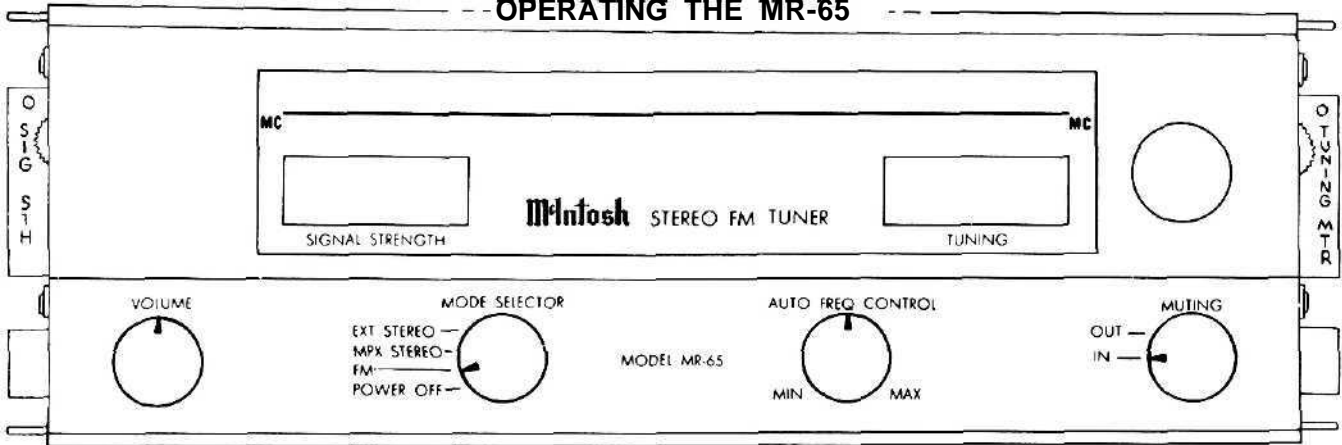

Fig. 21—Front Panel Controls.

#### MONOPHONIC FM PROGRAM

Turning the MODE SELECTOR to FM turns the MR-65 power on. Turn the VOLUME CONTROL to its mid point, the AUTO. FREQ. CONTROL all the way to the right, and the MUTING switch to the IN position. After a warm up of about 30 seconds turn the tuning knob to find the station of your choice.

While tuning the MR-65 you may notice the meters indicating a station yet no program is heard from the speakers. The muting circuit in the tuner is rejecting the station because there is objectionable noise with the weak signal from the station. Turn the MUTING switch to the OUT position and the station will be heard. Most programs that can be tuned in this manner are of poor quality due to interfering noise.

The AFC action is electrically delayed to permit tuning without AFC and without turning switches to disable the AFC. After tuning is complete the AFC automatically locks on the station. The MR-65 may be accurately tuned without having to "split hairs." The very best performance with a minimum of experience or effort results from the action of the new AFC circuit. For critical tuning, merely tune until a station is heard from the speaker, and then the AFC, after a few seconds delay, automatically centers the station on the channel.

If two stations are next to each other the AFC action may tend to capture and hold the stronger station. By

turning the AFC knob to the left the amount of AFC is reduced and the weaker station of the two can be tuned and held. The quality of the audio program is unaffected by the amount of AFC used.

#### STEREOPHONIC-INTERNAL MULTIPLEX (MPX)

After the MPX adapter has been installed in the prepared space on the chassis, MPX stereo broadcast programs can be received. Turn the MODE SELECTOR to MPX STEREO and use the rest of the controls as in "Monophonic FM Program" above. The volume control is not operating in this position.

When the MR-65 is tuned to any station broadcasting stereo the MPX adapter will separate the "left" and "right" channels for stereo reproduction by the loudspeakers.

#### STEREOPHONIC-EXTERNAL MULTIPLEX (MPX)

With an external multiplex adapter plugged in the MPX OUT jack all controls are set identically to the "Monophonic FM" settings.

#### STEREOPHONIC-FM-FM or FM-AM

With a separate tuner plugged in the STEREO IN-LEFT jacks and the MODE SELECTOR in the EXT STEREO position FM-FM or FM-AM stereo broadcast can be tuned. The MR-65 supplies the right channel program and the separate tuner supplies the left channel program.

## ADJUSTMENTS

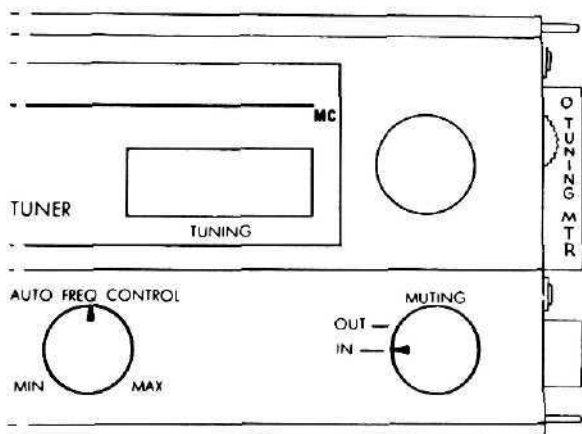

Fig. 22—TUNING meter adjustment.

### TUNING METER

The meter adjustments are made with the MR-65 turned on. Turn the MODE SELECTOR to the FM position, the MUTING switch to the OUT position, the AUTO. FREQ. CONTROL to the extreme left, and the VOLUME to a comfortable loudness. Turn the tuning knob so that the dial pointer is near the center of the dial scale but not on or near a station. The red knob under the right panel end cap centers the pointer in the TUNING meter. Turn the red knob until the pointer is in the center of the black area on the TUNING meter face.

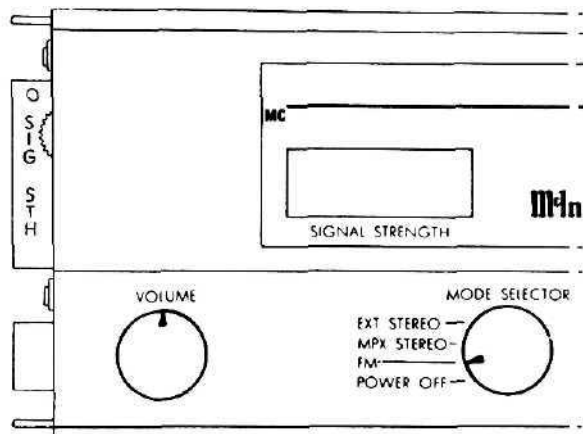

Fig. 23—SIGNAL STRENGTH meter adjustment.

### SIGNAL STRENGTH METER

The SIGNAL STRENGTH adjustment is the red knob under the left panel end cap. With the MR-65 still tuned as above adjust this red knob until the pointer moves over the zero (0) on the SIGNAL STRENGTH meter face. Both meters are now properly adjusted.

### DIAL LIGHTS

Adjustment of the dial scale lighting can be made on the rear of the chassis. Set the switch marked LAMPS for HI if you want more light, and LO if you want a dimmer light plus extended lamp life.

The MR-65 you have purchased will give you years of pleasant and satisfactory performance. If you have any questions concerning the operation or maintenance of this tuner please contact:

Customer Service  
McIntosh Laboratory Inc.  
2 Chambers Street  
Binghamton, New York

Our telephone number is 723-5491.  
The direct dial area code is 607.

## GUARANTEE

McIntosh Laboratory Incorporated guarantees the mechanical and electrical workmanship and components of this equipment to be free of defects for a period of 90 days from date of purchase. We further

guarantee this equipment to perform as advertised. This guarantee does not extend to components damaged by improper use nor does it extend to transportation to and from the factory.

### 3-YEAR FACTORY SERVICE CONTRACT

An application for a FREE 3-YEAR FACTORY SERVICE CONTRACT is included in the pocket on the back cover of this manual.



# McIntosh LABORATORY, INC.

2 CHAMBERS STREET, BINGHAMTON, N. Y.

Made in U.S.A.  
Phone-Area Code 607-723-5491